

eyepiece reticles

eyepiece reticles (graticules)

Definition:

An eyepiece reticle is a glass disc with a pattern on it that fits at the optical plane inside a microscope eyepiece. It is used to provide alignment, measurement, size or shape comparison, or area counting of specimens by having the reticle pattern superimposed over the specimen image.

The terms reticle, graticule and reticule are all used to describe these items.

Standard Patterns:

The following pages show the wide range of patterns that we have available. These include:

- Lines and cross-lines for alignment
- Scales and gauges for measurement
- Grids for counting and referencing
- Particle sizing to determine shape, size and quantity of materials or vapours
- Protractors for measuring angles
- Stereology for extracting quantitative information from 3D images
- Many specialist patterns designed by Scientists for specific applications

All Pyser eyepiece reticles are produced on 1.5mm thick optical glass. The image, which is created using a vacuum evaporated chrome process, is correct reading through the glass. All Pyser eyepiece reticles are available in a variety of standard diameters to suit most microscopes in the marketplace. Other sizes are available to special order.

Custom Patterns:

If you need something different from the patterns in this catalogue there is no problem, we have a very cost-effective custom reticle facility that is able to make the exact pattern you require.

history of the graticules division of pyser optics limited

Julius Rheinberg, a member of the Royal Society developed many techniques and processes associated with microphotography. He built the world's first colour camera, invented a grainless photographic emulsion and was well known in optical circles conducting much correspondence with eminent microscopists in Europe. Julius started making graticules for the British Government in 1914, using the skills he developed in photographic processing.

Leslie Rheinberg, the nephew of Julius Rheinberg, formed Graticules Limited in 1946. From 1946 to 1969 the Company operated from laboratories in London using established processes including pigmented fish glues, lead sulphide glass etching, grainless photography, and the introduction of vacuum coating and electroforming in later years.

In 1969 Graticules Limited moved to Tonbridge, taking on additional space in 1976. Expertise, knowledge and developments built up over nearly 100 years enables the Company to offer a comprehensive range of products for microscopy, optics, education, medicine/research, defence and industry.

Graticules Limited was purchased in 1997 by Pyser Optics Limited, a company producing specialised precision optical products since 1932, creating a powerful knowledgeable company manufacturing optics, optical instruments and electro-optical systems.

selecting your reticle:

There are two things that need to be defined when selecting your reticle:

1. The pattern that is suitable for your application
2. The diameter required to fit your eyepiece

The application or method that you are working to will normally determine the reticle pattern that will be required. For instance, if you are doing straightforward length measurements you may require a simple horizontal scale, if you are performing asbestos analysis you are most likely to need a Walton & Beckett reticle.

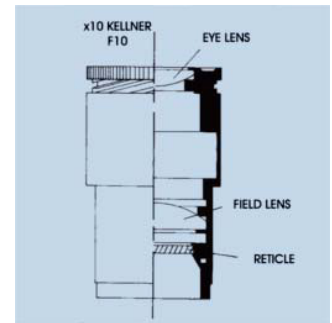

One very common mistake that is made when selecting the reticle is with the size of the pattern. If you have a 10mm length scale (such as our NE1) in the eyepiece this does not mean that it will be measure 10mm at the specimen stage. You have to take into account the objective magnification. Thus if you are using a 10x objective lens then the 10mm scale will represent 1mm at the specimen stage ($10\text{mm}/10\text{x} = 1\text{mm}$). In practical use, if you have a specimen of typically 50 micron (0.050mm) length and you are using a 40x objective then you will need to select a reticle pattern that has a scale range capable of measuring a size of 2mm ($0.050\text{mm} \times 40\text{x} = 2\text{mm}$).

The reticle is fitted inside the eyepiece at the optical plane. The optical plane being the position where both the formed images of the specimen and the reticle are in focus. The reticle diameter needs to be a fraction smaller than the inside diameter of the eyepiece at the point of the optical plane. Most modern eyepieces have a reticle holder or threaded bush to secure the reticle in the correct position. If there is no fixing device in the eyepiece then Pyser offer a measuring and fitting service.

measuring and fitting service:

When fitting reticles it is essential this is done in clean areas, any speck of dust on the reticle will be visible when installed in the microscope. The locating and securing of the reticle can also cause problems. Due to these difficulties and the uncertainty that many people have about sizing a reticle, Pyser Optics offer a measuring and fitting service.

Customers send us their eyepiece and we carry out the following actions:

1. Check to see if fitting a reticle is feasible and then measure the internal dimensions to determine the diameter required.
2. Provide a quotation for the supply and fitting of the reticle.
3. Once order/payment has been received Pyser will make and fit the reticle then despatch it back to you.

lines and crosses

single lines

NE 50

For measurement of large objects in conjunction with graduated mechanical stage, and for alignment. Image covers entire field of view.

pattern	description	diameter	order code
NE50	Single line, nominal width 0.02mm	16 mm	01B16238
		19 mm	01B19238
		21 mm	01B21238
		23 mm	01B23238
		24 mm	01B24238
		26 mm	01B26238
		27 mm	01B27238
		special	01BSP238

drawings not to scale

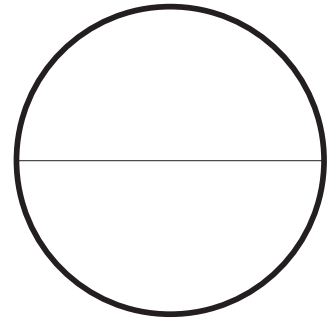

crosslines

NE 8, NE81, NE82

Used as for NE50 but for measurements in two directions and for sighting and alignment. Image covers entire field of view

pattern	description	diameter	order code
NE8	crosslines, normal line width 0.02 mm	16 mm	01B16206
		19 mm	01B19206
		21 mm	01B20206
		23 mm	01B21206
		24 mm	01B23206
		26 mm	01B26206
		27 mm	01B19206
		special	01BSP206

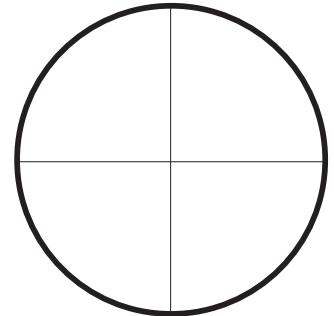

pattern	description	diameter	order code
NE81	crosslines, normal line width 0.04 mm	16 mm	01B16234
		19 mm	01B19234
		21 mm	01B21234
		23 mm	01B23234
		24 mm	01B24234
		26 mm	01B26234
		27 mm	01B27234
		special	01BSP234

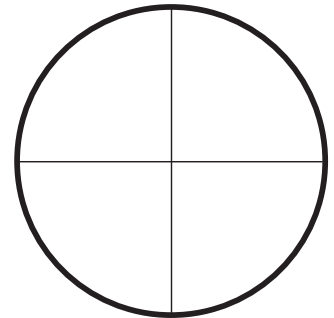

pattern	description	diameter	order code
NE82	crosslines, normal line width 0.005 mm	16 mm	01B16235
		19 mm	01B19235
		21 mm	01B21235
		23 mm	01B23235
		24 mm	01B24235
		26 mm	01B26235
		27 mm	01B27235
		special	01BSP235

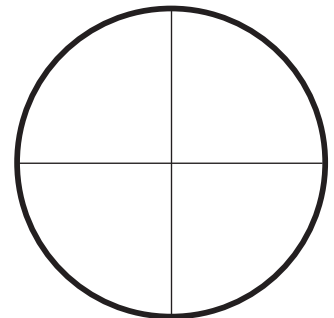

crosslines

NE 8, NE81, NE82

Use as crossed lines. Broken lines enable fine detail to be seen at the breaks. A thin boundary would be lost behind a continuous line.

pattern	description	diameter	order code
NE56	broken crossline	16 mm	01B16231
		19 mm	01B19231
		21 mm	01B21231
		23 mm	01B23231
		24 mm	01B24231
		26 mm	01B26231
		27 mm	01B27231
		special	01BSP231

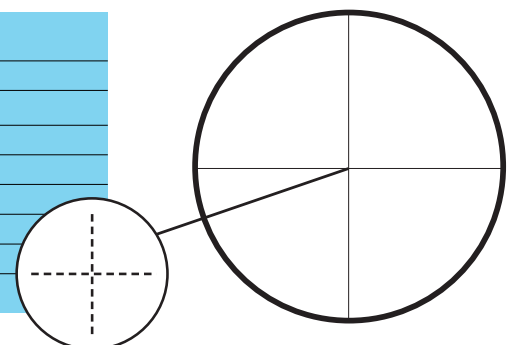

crossed gauge lines

drawings not to scale

NE 53, NE54

Use as crossed lines, but for measuring distances between lines. Greater accuracy can be obtained by locating the specimen detail between the reticle gauge pair. Image covers entire field of view.

pattern	description	diameter	order code
NE53	Two vertical lines 0.1 mm apart with horizontal line	16 mm	01B16230
		19 mm	01B19230
		21 mm	01B21230
		23 mm	01B23230
		24 mm	01B24230
		26 mm	01B26230
		27 mm	01B27230
		special	01BSP230

pattern	description	diameter	order code
NE54	Two vertical lines 0.2 mm apart	16 mm	01B16239
		19 mm	01B19239
		21 mm	01B21239
		23 mm	01B23239
		24 mm	01B24239
		26 mm	01B26239
		27 mm	01B27239
		special	01BSP239

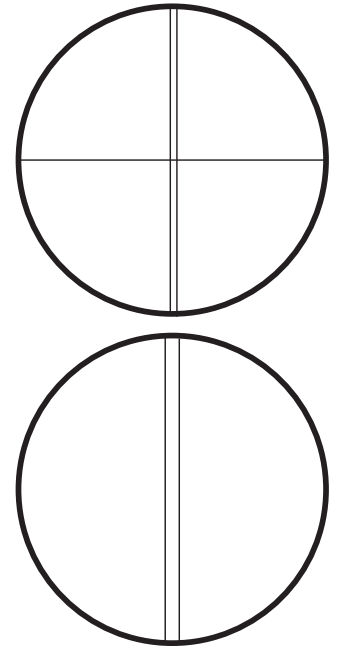

eyepiece scales

horizontal & vertical scales

drawings not to scale

NE1, NE2, NE5, NE20 NE28, NE31, NE41, NE120

Used for measuring lengths of specimen or distances between points on a variety of different shaped objects

pattern	description	diameter	order code
NE120	Horizontal micrometer 20mm long, with 200 divisions of 0.1mm	23 mm	01B23320
		24 mm	01B24320
		26 mm	01B26320
		27 mm	01B27320
		special	01BSP320

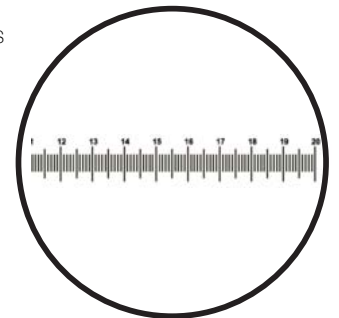

NE1 Scale: This eyepiece reticle has an overall length of 10.00mm with 100 subdivisions of 0.1mm. When used with a x10 objective each division will represent 10 microns on the specimen. By dividing the division of the chosen reticle by the magnification of the objective one obtains an approximate value that each division will represent on the stage.

pattern	description	diameter	order code
NE1	Vertical micrometer 10mm long, with 100 divisions of 0.1mm	16 mm	01B16201
		19 mm	01B19201
		20 mm	01B20201
		21 mm	01B21201
		23 mm	01B23201
		24 mm	01B24201
		26 mm	01B26201
		27 mm	01B27201
special	01BSP201		

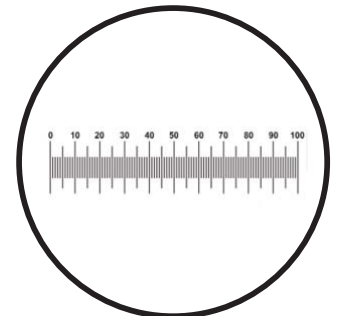

pattern	description	diameter	order code
NE2	Horizontal micrometer 5mm long, with 100 divisions of 0.05mm	16 mm	01B16203
		19 mm	01B19203
		21 mm	01B21203
		23 mm	01B23203
		24 mm	01B24203
		26 mm	01B26203
		27 mm	01B27203
special	01BSP203		

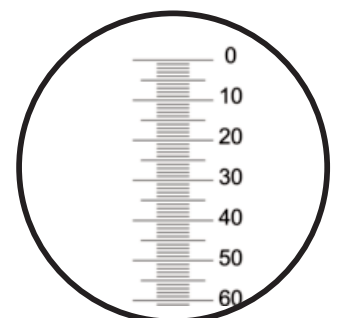

pattern	description	diameter	order code
NE5	Horizontal micrometer 5mm long,	16 mm	01B16203
	with 100 divisions of 0.05mm	19 mm	01B19203
		21 mm	01B21203
		23 mm	01B23203
		24 mm	01B24203
		26 mm	01B26203
		27 mm	01B27203
		special	01BSP203

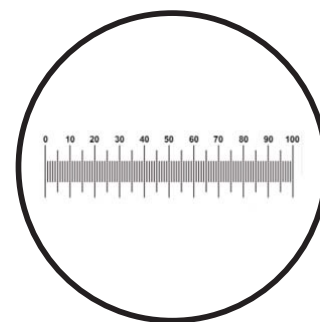

eyepiece scales

horizontal & vertical scales

NE 50

Used for measuring lengths of specimen or distances between points on a variety of different shaped objects.

pattern	description	diameter	order code
NE28	Horizontal scale 1mm long,	16 mm	01B16217
	with 100 divisions of 0.01mm.	19 mm	01B19217
		21 mm	01B21217
		23 mm	01B23217
		24 mm	01B24217
		26 mm	01B26217
		27 mm	01B27217
		special	01BSP217

drawings not to scale

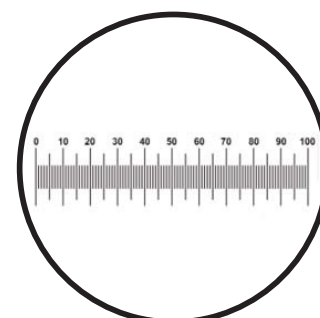

pattern	description	diameter	order code
NE41	Horizontal scale 10mm long,	16 mm	01B16223
	with 200 divisions of 0.05mm.	19 mm	01B19223
		21 mm	01B21223
		23 mm	01B23223
		24 mm	01B24223
		26 mm	01B26223
		27 mm	01B27223
		special	01BSP223

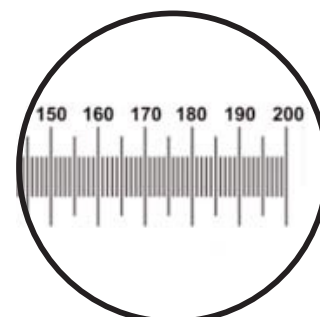

pattern	description	diameter	order code
NE20	Horizontal scale 0.1" long,	16 mm	01B16214
	with 100 divisions of 0.001mm.	19 mm	01B19214
		21 mm	01B21214
		23 mm	01B23214
		24 mm	01B24214
		26 mm	01B26214
		27 mm	01B27214
		special	01BSP214

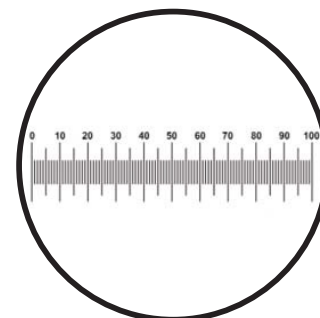

pattern	description	diameter	order code
NE31	Horizontal scale 0.5" long,	16 mm	01B16219
	with 100 divisions of 0.005"	19 mm	01B19219
		21 mm	01B21219
		23 mm	01B23219
		24 mm	01B24219
		26 mm	01B26219
		27 mm	01B27219
		special	01BSP219

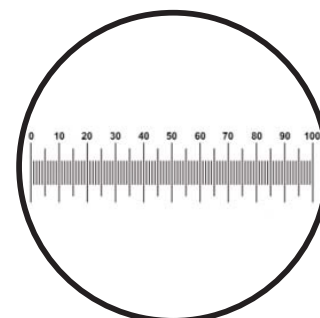

eyepiece scales

crossed scales

NE 17, NE18

Used as horizontal and vertical scales, and especially useful when interested in measurements in different axis

pattern	description	diameter	order code
NE17	Crossed micrometer scales. Each 10 mm long with 100 divisions of 0.1 mm	16 mm	01B16212
		19 mm	01B19212
		20 mm	01B20212
		21 mm	01B21212
		23 mm	01B23212
		24 mm	01B24212
		26 mm	01B26212
		27 mm	01B27212
special	01BSP212		

pattern	description	diameter	order code
NE18	Crossed micrometer scales. Each 5 mm long with 100 divisions of 0.05 mm	16 mm	01B16213
		19 mm	01B19213
		21 mm	01B21213
		23 mm	01B23213
		24 mm	01B24213
		26 mm	01B26213
		27 mm	01B27213
		special	01BSP213

pattern	description	diameter	order code
NE72	Crossed micrometer scales. Each 20 mm long with 200 divisions of 0.1 mm	23 mm	01B23303
		24 mm	01B24303
		26 mm	01B26303
		27 mm	01B27303
		special	01BSP303

pattern	description	diameter	order code
NE70	Crossed micrometer scales. (imperial) Each 0.8" long with 400 divisions of 0.002"	21 mm	01B21301
		23 mm	01B23301
		24 mm	01B24301
		26 mm	01B26301
		27 mm	01B27301
		special	01BSP301

drawings not to scale

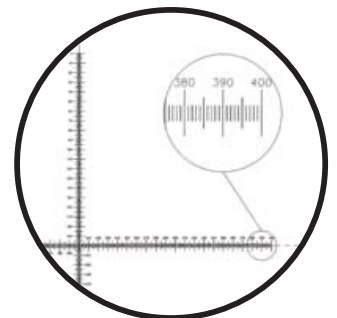
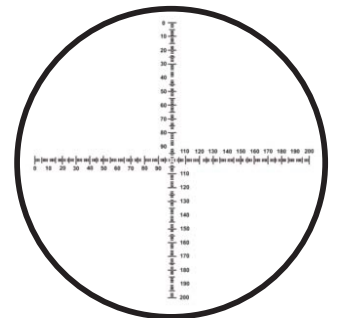
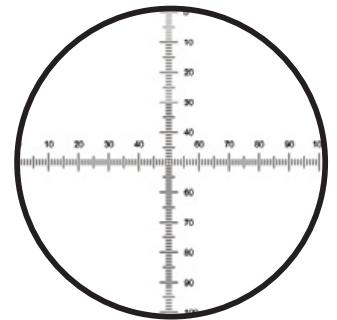
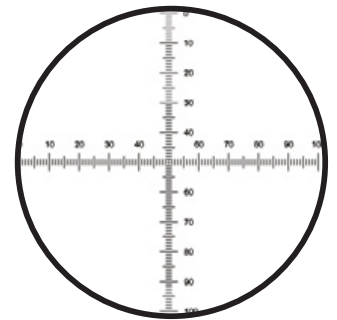

Part scale shown

scales with crosslines

NE 7, NE 7N

The inclusion of a crossline assists in ensuring alignment of the reticle with edges, etc, in the specimen.

pattern	description	diameter	order code
NE7	Horizontal scale 1mm long, with 100 divisions of 0.01mm.	16 mm	01B16217
		19 mm	01B19217
		21 mm	01B21217
		23 mm	01B23217
		24 mm	01B24217
		26 mm	01B26217
		27 mm	01B27217
special	01BSP217		

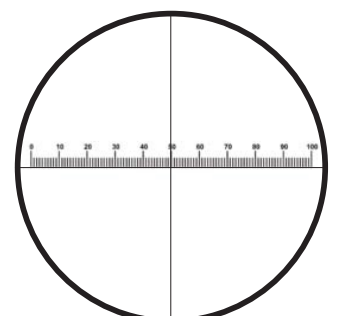

pattern	description	diameter	order code
NE7N	Horizontal micrometer scale 10mm long,	16 mm	01B16205
	with 100 divisions of 0.1mm, includes,	19 mm	01B19205
	crosslines and additional 10mm square	21 mm	01B21205
		23 mm	01B23205
		24 mm	01B24205
		26 mm	01B26205
		27 mm	01B27205
		special	01BSP205

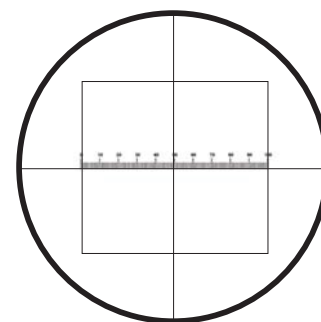

scale with crosslines

NE77, NE777

The inclusion of a crossline assists in ensuring alignment of the reticle with edges, etc, in the specimen.

pattern	description	diameter	order code
NE77	Horizontal micrometer scale 5mm long,	16 mm	01B16233
	with 100 divisions of 0.05mm and	19 mm	01B19233
	crosslines	21 mm	01B21233
		23 mm	01B23233
		24 mm	01B24233
		26 mm	01B26233
		27 mm	01B27233
		special	01BSP233

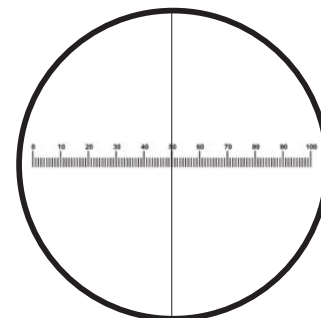

pattern	description	diameter	order code
NE777	Horizontal micrometer scale 5" long,	16 mm	01B16237
	with divisions of 0.005" and	19 mm	01B19237
	crosslines	21 mm	01B21237
		23 mm	01B23237
		24 mm	01B24237
		26 mm	01B26237
		27 mm	01B27237
		special	01BSP237

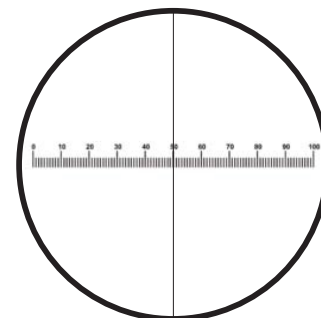

squares and grids

Note: These may need to be calibrated, according to intended use. There are a number of uses for the grids and squares listed and they will largely depend on the individual user's application.

Sectoring

A squared reticle might be used for the systematic examination of a specimen. Some of the squared patterns are numbered to aid the identification of areas of interest. Sectoring is particularly useful for making drawings of specimens onto graph paper. The chessboard type of pattern helps the user to distinguish the position being examined: the darker squares are translucent, while the lighter ones are transparent, avoiding eyestrain in prolonged counting as may be necessary in haematology. These patterns provide the same advantages when used with image analysis and capture devices.

Counting

A squared reticle can be used for counting. Here the basic principle is that a small area of the specimen is analysed in order to obtain information about the total area. This minimises sometimes wasteful work enabling simple analysis of a particular area. An example of this would be the comparison of large to small particles in a specimen. By using the Miller reticle (NE57) only the smaller particles in the small square are counted, the result being multiplied by ten for comparison with the number of larger particles in the large square.

Squared Grids

Squared grids can be used in particle size analysis as simple technical aids where sophisticated image analysis systems are not required. The areas of the particles to be measured can be estimated by simply counting the number of squares occupied by those particles. It is necessary to estimate fractions of a square or make a rule (e.g. count as a square all partly covered squares at the right and bottom sides of the grid, and ignore partly covered squares at the left and upper sides of the square). This method would only be useful for a fairly crude estimation of a large diameter. For more detailed optical analysis it is advisable to use a specialised reticle such as those in the Particle Size Analysis section on page 11.

squared grids

NE 10, NE11, NE34 Simple grids are convenient for making sketches of the observed specimen. They are also useful for particle counting. NE10 and NE11 grids cover the full area. NE34 grid is 10mm x10mm.

pattern	description	diameter	order code
NE10	Grid (net) 0.5mm pitch	16 mm	01B16207
		19 mm	01B19207
		21 mm	01B21207
		23 mm	01B23207
		24 mm	01B24207
		26 mm	01B26207
		27 mm	01B27207
		special	01BSP207

pattern	description	diameter	order code
NE11	Grid (net) 1.0mm pitch	16 mm	01B16209
		19 mm	01B19209
		21 mm	01B21209
		23 mm	01B23209
		24 mm	01B24209
		26 mm	01B26209
		27 mm	01B27209
		special	01BSP209

pattern	description	diameter	order code
NE34	10 mm x 10 mm grid of 0.1 mm square	16 mm	01B16300
		19 mm	01B19300
		21 mm	01B21300
		23 mm	01B23300
		24 mm	01B24300
		26 mm	01B26300
		27 mm	01B27300
		special	01BSP300

indexed grids

NE 10A, NE 11A, NE34A Useful for particle counting, particularly where reference is needed between workers. Also useful for area of specimen determinations.

pattern	description	diameter	order code
NE10A	Numbered grid 5mm x 5mm 0.5 mm pitch. Marketed 1-10 and A-J	16 mm	01B16208
		19 mm	01B19208
		21 mm	01B21208
		23 mm	01B23208
		24 mm	01B24208
		26 mm	01B26208
		27 mm	01B27208
		special	01BSP208

pattern	description	diameter	order code
NE11A	Numbered grid 10mm x 10mm 1.0 mm pitch. Marketed 1-10 and A-J	16 mm	01B16210
		19 mm	01B19210
		21 mm	01B21210
		23 mm	01B23210
		24 mm	01B24210
		26 mm	01B26210
		27 mm	01B27210
		special	01BSP210

pattern	description	diameter	order code
NE34A	Numbered grid 1mm x 1mm 0.1 mm pitch. Marketed 1-10 and A-J	16 mm	01B16214
		19 mm	01B19214
		21 mm	01B21214
		23 mm	01B23214
		24 mm	01B24214
		26 mm	01B26214
		27 mm	01B27214
		special	01BSP214

drawings not to scale

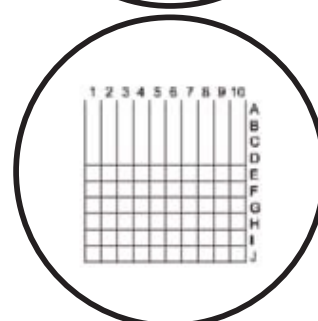
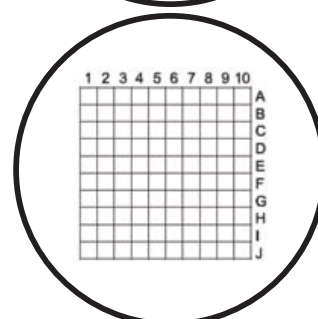
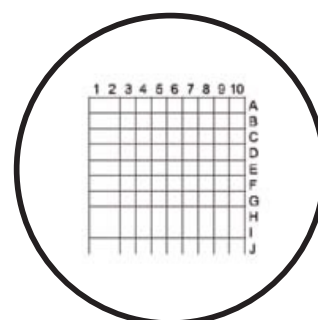
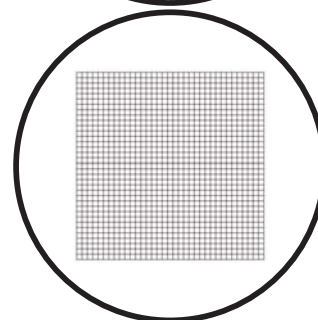
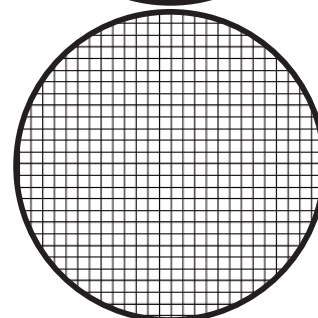
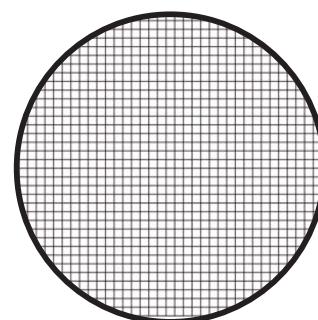

indexed grids

NE71, NE35

NE 35 - Useful for particle counting, particularly where reference is needed between workers, especially rectangular shapes, also for particle counting.

pattern	description	diameter	order code
NE71	Index pattern 20 x 20 grid of 0.5 mm squares	21 mm	01B21302
		23 mm	01B23302
		24 mm	01B24302
		26 mm	01B26302
		27 mm	01B27302
		special	01BSP302

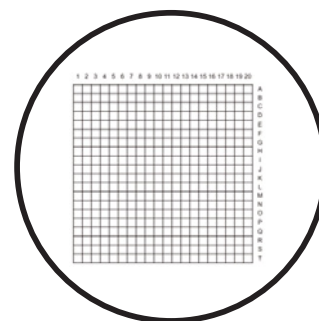

pattern	description	diameter	order code
NE35	Index pattern 10 mm x 10 mm 1mm indexed squares	16 mm	01B16237
		19 mm	01B19237
		21 mm	01B21237
		23 mm	01B23237
		24 mm	01B24237
		26 mm	01B26237
		27 mm	01B27237
		special	01BSP237

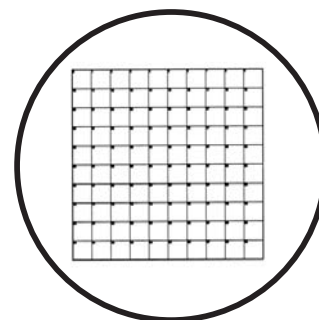

chessboard squares

NE15

The dark squares are translucent. Used as an alternative to simple grids for area of specimen determination and particle counting. Alternate light and dark squares help to reduce eyestrain. Semi coating gives approximately 50% light transmission.

pattern	description	diameter	order code
NE15	Chessboard (net) 2.0 mm squares	16 mm	01B16211
		19 mm	01B19211
		21 mm	01B21211
		23 mm	01B23211
		24 mm	01B24211
		26 mm	01B26211
		27 mm	01B27211
special	01BSP211		

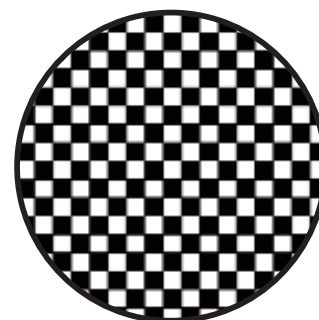

scale with crosslines

NE38 Combines three areas in one for convenience, giving area ratios A:B of 1:3 and B:C of 1:2.

pattern	description	diameter	order code
NE77	Squares 10mm, 7mm & 4mm	16 mm	01B16222
		19 mm	01B19222
		21 mm	01B21222
		23 mm	01B23222
		24 mm	01B24222
		26 mm	01B26222
		27 mm	01B27222
		special	01BSP222

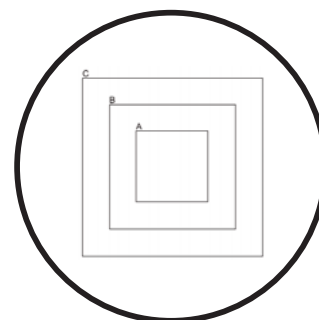

millor squares

NE57 The ratio of large to small square is 9:1. Originally designed for haematology, they can be utilised for rapid counting of any evenly spread field of particles. References: American Journal of Clinical Pathology Vol. 20, 1950, page 1079. "Time Saving Device For Counting Reticulocyte." G. Brescher and Schneiderman. Practical Haematology-J.D. Dacy. Published by J.A. Churchill. 2nd Edition 1956

pattern	description	diameter	order code
NE57	Miller 7 x 7 mm grid	16 mm	01B16232
		19 mm	01B19232
		21 mm	01B21232
		23 mm	01B23232
		24 mm	01B24232
		26 mm	01B26232
		27 mm	01B27232
		special	01BSP232

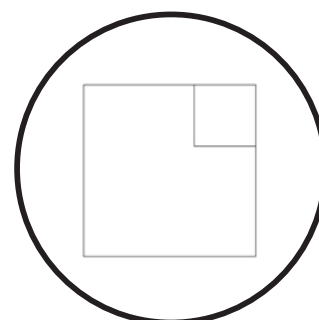

whipple grid

NE 29

Originally designed for water particle analysis, but may be used for other aspects of particle counting. Grid shown: Ratio of full square to smallest is 50:1. Area is 2500:1 Reference: Microscopy of Drinking Water. NB - NE29 is also available with a 10 mm x 10 mm grid.

pattern	description	diameter	order code
NE29	Whipple grid 100 squares in	16 mm	01B16218
	7 mm area	19 mm	01B19218
		21 mm	01B21218
		23 mm	01B23218
		24 mm	01B24218
		26 mm	01B26218
		27 mm	01B27218
		special	01BSP218

drawings not to scale

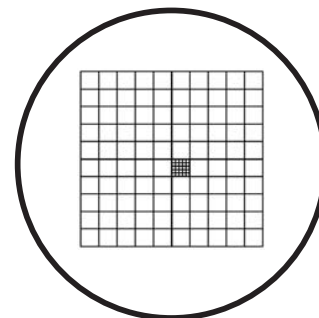

circle gauges and protractors

concentric circles

NE42, NE43, NE44, NE47

Can be used for two-way measurement when calibrated as a micrometer.

drawings not to scale

pattern	description	diameter	order code
NE42	Concentric circles 0.25 mm -	16 mm	01B16224
	2.5 mm diameter. 10 circles	19 mm	01B19224
		21 mm	01B21224
		23 mm	01B23224
		24 mm	01B24224
		26 mm	01B26224
		27 mm	01B27224
		special	01BSP224

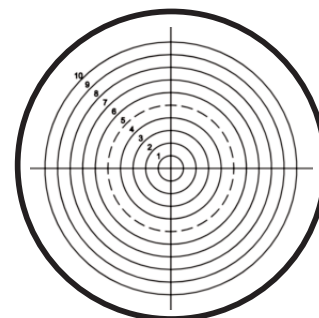

pattern	description	diameter	order code
NE43	Concentric circles 0.5 mm -	16 mm	01B16225
	5 mm diameter. 10 circles	19 mm	01B19225
		21 mm	01B21225
		23 mm	01B23225
		24 mm	01B24225
		26 mm	01B26225
		27 mm	01B27225
		special	01BSP225

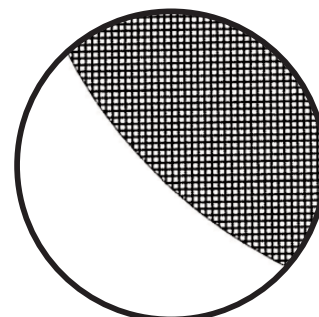

pattern	description	diameter	order code
NE44	Concentric circles 1 mm -	16 mm	01B16226
	10mm diameter. 10 circles	19 mm	01B19226
		21 mm	01B21226
		23 mm	01B23226
		24 mm	01B23226
		26 mm	01B26226
		27 mm	01B27226
		special	01BSP226

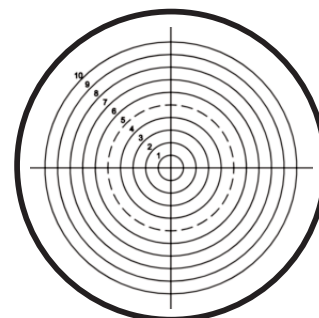

pattern	description	diameter	order code
NE47	Concentric circles 2 mm -	21 mm	01B21228
	20mm diameter. 10 circles	23 mm	01B23228
		24 mm	01B24228
		26 mm	01B26228
		27 mm	01B27228
		special	01BSP228

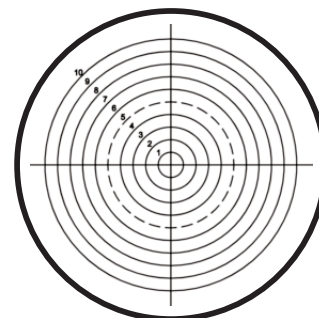

concentric circles + cross scales

NE48 Similar to concentric circles, but with graduated cross hairs.

pattern	description	diameter	order code
NE48	Concentric circles 1 mm - 10mm diameter. 10 circles, with graduated cross hairs	16 mm 19 mm 21 mm 23 mm 24 mm 26 mm 27 mm special	01B16242 01B19242 01B21242 01B23242 01B24242 01B26242 01B27242 01BSP242

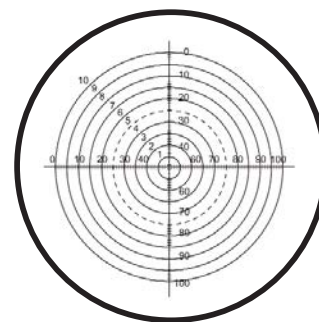

concentric circles

NE22 This design leaves the circles clear of obstruction. In addition the intermediate lines are broken to improve ease of reading.

pattern	description	diameter	order code
NE22	Concentric circles 0.5 mm - 12mm diameter. 24 circles	16 mm 19 mm 21 mm 23 mm 24 mm 26 mm 27 mm special	01B16215 01B19215 01B21215 01B23215 01B24215 01B26215 01B27215 01BSP215

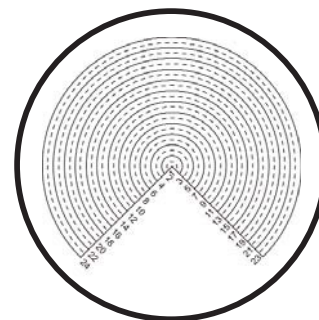

gauge pairs

NE19 Gauge pairs occupying a field of view of 10mm. Each gauge is proportional to its adjacent number. Approx size of smallest pair = 0.1mm.

pattern	description	diameter	order code
NE19	Gauge pairs	16 mm 19 mm 21 mm 23 mm 24 mm 26 mm 27 mm special	01B16241 01B19241 01B21241 01B23241 01B24241 01B26241 01B27241 01BSP241

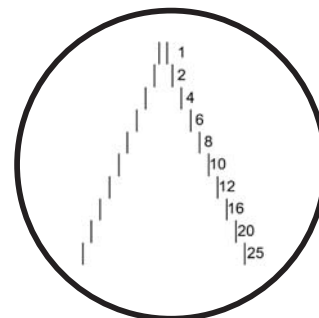

protractors

Placed in the eyepiece, these are used in the same manner as ordinary protractors.

half protractor

pattern	description	diameter	order code
NE25	Half protractor scale 10 mm diameter divided in degrees.	16 mm 19 mm 21 mm 23 mm 24 mm 26 mm 27 mm special	01B16216 01B19216 01B21216 01B23216 01B24216 01B26216 01B27216 01BSP216

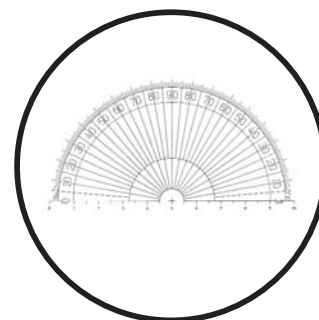

full protractor

pattern	description	diameter	order code
NE45	Full protractor scale 10mm diameter 16mm divided in degrees.	16 mm 19 mm 21 mm 23 mm 24 mm 26 mm 27 mm special	01B16227 01B19227 01B21227 01B23227 01B24227 01B26227 01B27227 01BSP227

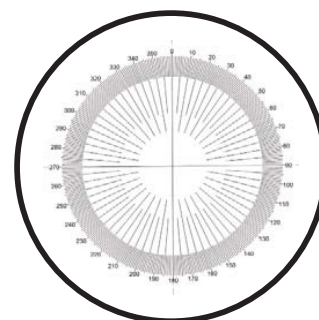

particle sizing and distribution

The use of the eyepiece reticles shown in this section make it possible to analyse specimens containing particles as an alternative, or in addition to, sieving. Reticles for particle size analysis are particularly popular when there are only limited quantities of particles or where particles are smaller than 50 micron diameter. Typical substances analysed are sand grains, soil particles, plant seeds, fertilizers, abrasives, liquid droplets, pigments, pulverised coal, silica, fibres and fine dust.

The basic principle employed is to compare particles to the globes and circles of varying sizes that appear on the reticle – dark particles being compared to solid globes, and light or transparent ones to the circles. Naturally the procedure varies with the reticle concerned, more information about which is given alongside each reticle description.

Please note that for calibration the circles and globes will represent particles smaller in diameter by the magnification of the objective.

patterson globes and circles

drawings not to scale

NG 1

The reticle consists of a central rectangle, sub-divided into nine smaller rectangles with a number of increasing circles outside the top and bottom horizontal edges. The marked figures are the diameters of the circles in units. 250 units represent the horizontal length of the large rectangle.

Rectangle size is 4.5mm x 2.025mm. Circle sizes in microns are nominally 450, 360, 270, 225, 180, 145, 110, 74, 37 and 18. Reference: H.S.Patterson and W.Cawood. Transactions of the Faraday Society, Vol. 32 Feb 1936. "The Determination of Size Distribution in Smokes." Pp. 1084-1088.

pattern	description	diameter	order code
NG1	Patterson globes/ circles	16 mm	01B16250
		19 mm	01B19250
		21 mm	01B21250
		23 mm	01B23250
		24 mm	01B24250
		26 mm	01B26250
		27 mm	01B27250
		special	01BSP250

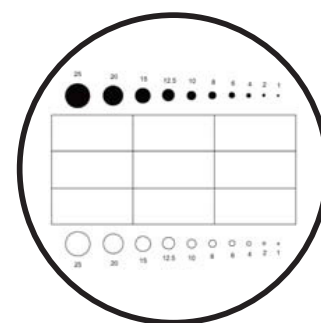

porton

NG 2

The circle areas of the Porton reticles increase with Root 2 progression as do the divisions on the right hand side of the rectangle. These divisions are numbered for convenience. Rectangle size is 4.5mm x 2.025mm. The specimen is racked on the mechanical stage of the microscope and traverses are taken right across the deposit sizing all the particles encountered.

Reference: K.R.May, Journal of Scientific Instruments Vol. 22 Oct 1945. "The Cascade Impactor." An instrument for sampling coarse aerosols.

pattern	description	diameter	order code
NG2	Original porton globes/ circle	16 mm	01B16251
		19 mm	01B19251
		21 mm	01B21251
		23 mm	01B23251
		24 mm	01B24251
		26 mm	01B26251
		27 mm	01B27251
special	01BSP251		

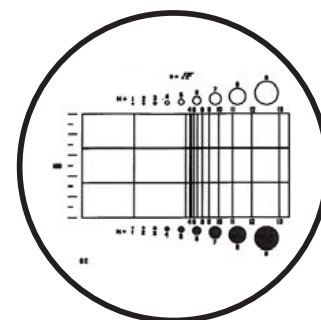

new portin

drawings not to scale

NG 12

The NG12 is particularly useful since the array of globes and circles are conveniently close to where the particles pass. At the end of each band of the sample the mechanical stage is traversed vertically to take in the next band until the whole sample has been covered.

Reference: K.R.May, Journal of Scientific Instruments Vol. 42 1965. "A New Graticule for Particle Counting and Sizing." Pp 500-501.

pattern	description	diameter	order code
NG12	Modified porton pattern	16 mm	01B16253
	globes/ circles	19 mm	01B19253
		21 mm	01B21253
		23 mm	01B23253
		24 mm	01B24253
		26 mm	01B26253
		27 mm	01B27253
		special	01BSP253

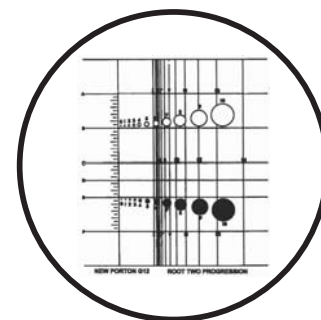

british standard reticle

NG 10

In this reticle the circle areas double progressively, hence the diameters alter by Root 2, so that the size classes can form a continuation of the standard series of sieves for particle sizing. Each particle is assigned to a size class defined by two adjacent circles which represent the size limits of that class. Thus the distribution of size is obtained in terms of the diameter of circles having the same projected area as the particles. This method will cover particles in the range 150 micron to 0.38 micron. The size distributions with respect to their number and weight are determined separately. Final results are calculated as cumulative percents. Actual size of circles and globes are nominally 560 μ , 400 μ , 280 μ , 200 μ , 149 μ , 100 μ and 70 μ .

Circle1 is defined as 1unit. Originally designed by the National Coal Board for use in coal mining. References: BS3625/BS3260

pattern	description	diameter	order code
NG10	British standard (BS3625/ BS3260)	16 mm	01B16252
	globes and circles	19 mm	01B19252
		21 mm	01B21252
		23 mm	01B23252
		24 mm	01B24252
		26 mm	01B26252
		27 mm	01B27252
		special	01BSP252

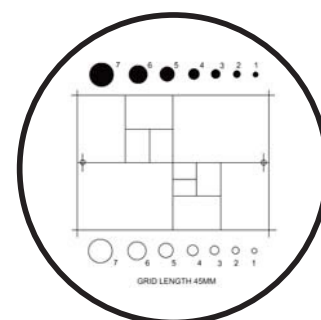

fairs

NG 5

Designed to extend the sizing range of globe and circle reticles. Example: Used in conjunction with NG2 the overall size range = 128:1. The circles increase by root 2. Note that both reticles would have to be used with the same microscope, eyepiece and objective.

Reference: G.L Fairs Chem Ind. 1943 Vol. 62. Pp 374-378. "The Use Of The Microscope In Particle Size Analysis."

pattern	description	diameter	order code
NG5	Fairs.	16 mm	01A16077
		19 mm	01A19077
		21 mm	01B21077
		23 mm	01A23077
		24 mm	01A24077
		26 mm	01A26077
		27 mm	01A27077
		special	01BSP077

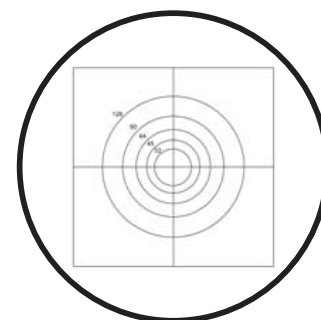

G 22, G24

Calibration factors are required for each of these reticles, see note below. The Walton and Beckett reticle is used for counting fibrous dust (e.g. asbestos or glass fibres) and is particularly useful where the majority of fibres to be counted are shorter than 5 micron. The circle is divided into four by two diametrical lines scaled in units of 5 and 3 microns respectively. 3 and 5 microns are the critical measurements of fibre lengths and diameter used in fibre counting. Unlike the usual globes of other particle reticles the Walton and Beckett has a series of shapes to compare objects with. These shapes have been designed for comparison with fibres, especially since they incorporate an aspect ratio of 3:1 or 5:1 essential for such analysis. Reference: W.H.Walton and S.T.Beckett. Occupational Hygiene. Vol. 20 pp 19-23.

"A Microscope Eyepiece For The Evaluation of Fibrous Dusts."

pattern	description	diameter	order code
G22	Walton & Beckett for asbestos.	16 mm	01A16062
	3:1 ratio.	19 mm	01A19062
		21 mm	01B21062
		23 mm	01A23062
		24 mm	01A24062
		26 mm	01A26062
		27 mm	01A27062
		special	01BSP062

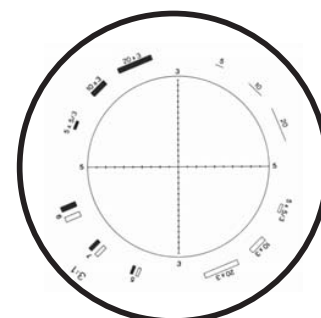

pattern	description	diameter	order code
G24	Walton & Beckett for asbestos.	16 mm	01B16063
	5:1 ratio.	19 mm	01B19063
		21 mm	01B21063
		23 mm	01B23063
		24 mm	01B24063
		26 mm	01B26063
		27 mm	01B27063
		special	01BSP063

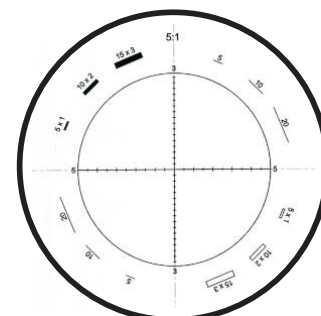
**G25**

Based on the G22, the G25 is produced to a new design by the Institute of Occupational Health.

pattern	description	diameter	order code
G25	Walton & Beckett for asbestos.	16 mm	01A16085
	(1996)	19 mm	01A19085
		21 mm	01B21085
		23 mm	01A23085
		24 mm	01A24085
		26 mm	01A26085
		27 mm	01A27085
		special	01BSP085

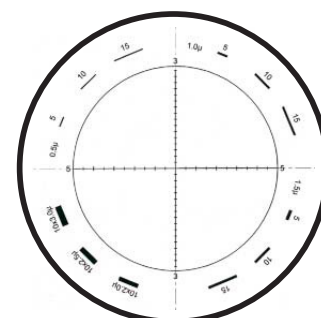

IMPORTANT NOTE. The circle on these Walton & Beckett reticles must represent 100 microns at the stage and each one must be manufactured to suit the individual instrument. Therefore, details should be provided with your order of :- Calibration factor, if known or Objective magnification, eyepiece magnification, diameter of reticle disc required, microscope make and model.

All Walton & Beckett reticles are normally used with 40x objectives giving a calibration factor of 4. In some microscopes there is also an additional 1.25x magnification to give a total objective magnification of 50x - these will have a calibration factor of 5. All standard Walton & Beckett reticles are supplied with a calibration factor of 4. Other calibration factors are made to special order. These reticles will require a calibrated stage micrometer to verify the sizes - See S12 or PS12 in Calibration Standards Brochure. For phase contrast verification see also S84.

specialist designs

spray droplet sizing reticle (matthews)

NG30

For size and distribution assessments of aerosol droplets. Used in conjunction with the Pyser 40x microscope for direct measurements of droplets from 50 to 400 microns diameter.

Actual pattern sizes are 50, 100, 200 and 400 microns. W.H.O. (Details on request) and G.A. Mathews. Imperial College.

pattern	description	diameter	order code
NG30	Matthew's spray droplet.	16 mm	01B16261
		19 mm	01B19261
		21 mm	01B21261
		23 mm	01B23261
		24 mm	01B24261
		26 mm	01B26261
		27 mm	01B27261
		special	01BSP261

drawings not to scale

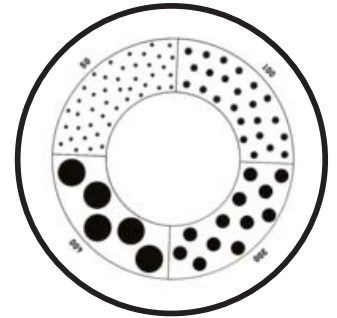

thompson

G23

For counting particles in any of three areas of known size. The graticule is calibrated in the same manner as a normal eyepiece scale. The result is then used to calculate the area of any square.

pattern	description	diameter	order code
G23	Thompson for dust analysis. 10mm,	16 mm	01A16056
	7mm and 4mm squares with 10mm	19 mm	01A19056
	scale in 0.1mm divisions and cross	21 mm	01A21056
	lines	23 mm	01B23056
		24 mm	01A24056
		26 mm	01A26056
		27 mm	01A27056
		special	01BSP056

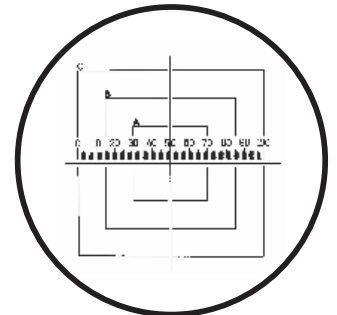

chalkley point array

NG52

This is used to quickly determine the relationship of components to each other using random sampling. An example of its application is given by Curtis, where a researcher might want to see whether or not a certain drug affects the volume proportion of cell types in a given organ. With this reticle the proportion of points lying over the image of one type of component is statistically proportional to the area occupied by that component. The 25 points of the array are placed over the field of view at random, so that a comparison can be made between the number of points touching the one type of component, with the number touching the other type of component in each viewing. A series of observations will yield an increasingly accurate ratio of the comparative incidence of each type of particle. Ref. A.S.C.Curtis. Medical and Biological Illustration, Vol. 10. pp 261- 266. "Area and Volume Measurements by Random Sampling Methods"

pattern	description	diameter	order code
NG52	Chalkley point array	16 mm	01B16257
		19 mm	01B19257
		21 mm	01B21257
		23 mm	01B23257
		24 mm	01B24257
		26 mm	01B26257
		27 mm	01B27257
		special	01BSP257

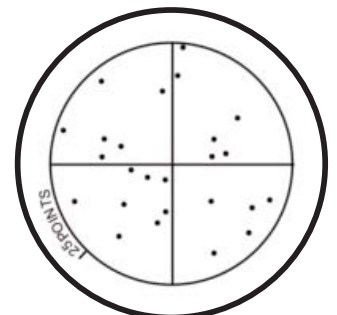

pharmaceutical PSA pattern

drawings not to scale

G57

This reticle was designed for the pharmaceutical industry. However, it is also useful where particle size considerations are restricted to 10 μ and 25 μ . Dots and circles give quick references for these two sizes. In addition a scale is incorporated.

The microscope must be calibrated when ordering this reticle, such that the circle must equate to 1mm on the microscope stage.

Reference: The United States Pharmaceutical Conventions Inc. Pharmaceutical Forum Vol.19 No.6.

This reticle is normally used with a 10x objective: calibration factor of 1. If a different objective magnification is used then a calibration factor will be needed to allow us to make it to the correct size. S8 and PS8 are recommended stage micrometers for use with this reticle.

pattern	description	diameter	order code
G57	pharmaceutical PSA pattern	19 mm	01A19076
		21 mm	01A21076
		23 mm	01A23076
		24 mm	01A24076
		26 mm	01A26076
		27 mm	01A27076
		special	01ASP076

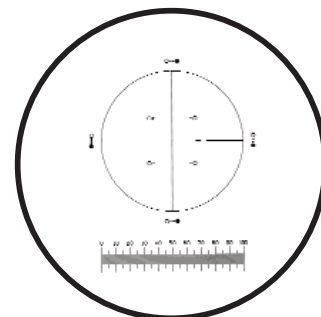

counting pattern

NG14

Simple counting for geological and soil analysis.

Reference: L.G.Briarty. "Stereology : Methods for Quantitative Light and Electron Microscopy." Sci. Prog. Oxf. 1975 62; 1-32

pattern	description	diameter	order code
NG14	Counting pattern for soil analysis.	16 mm	01B16254
	10mm square.	19 mm	01B19254
		21 mm	01B21254
		23 mm	01B23254
		24 mm	01B24254
		26 mm	01B26254
		27 mm	01B27254
		special	01BSP254

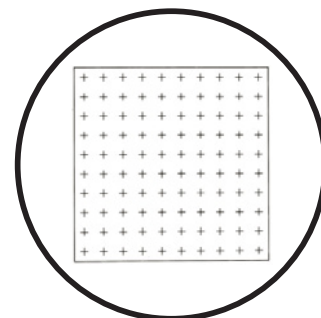

lennox grain analysis

NG21

pattern	description	diameter	order code
NG14	Lennox for grain analysis	16 mm	01B16255
		19 mm	01B19255
		21 mm	01B21255
		23 mm	01B23255
		24 mm	01B24255
		26 mm	01B26255
		27 mm	01B27255
		special	01BSP255

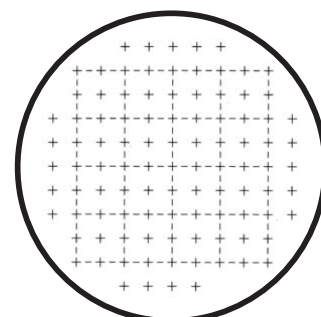

kotter

G48

Reference: I.S.O. 7404-4: 1988 (E). Methods for Analysis of Bituminous Coal and Anthracite. Part 4 and Methods of Determining Microlitho- type Composition. Normally used with 20x objective = calibration factor of 1. For use with 40x objective specify calibration factor of 2, for 50x specify 2.5. For other objective magnifications the reticle will need to be custom made.

pattern	description	diameter	order code
G48	Kotter pattern. Note: This pattern requires a calibration factor.	16 mm	01A16072
		19 mm	01A19072
		21 mm	01A21072
		23 mm	01B23072
		24 mm	01A24072
		26 mm	01A26072
		27 mm	01A27072
		special	01BSP072

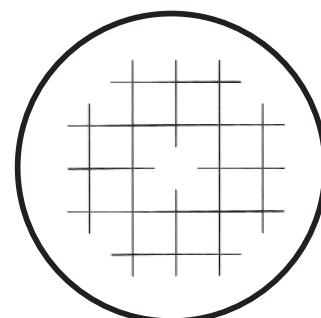

zeiss integrating eyepiece disc 1 or Henning Reseau pattern 25 points

G49 Reference: Zeiss Werkzeitschrift.

pattern	description	diameter	order code
G49	Henning Reseau pattern.	16 mm	01A16073
	(Zeiss intergrating disc 1)	19 mm	01A19073
		21 mm	01B21073
		23 mm	01A23073
		24 mm	01A24073
		26 mm	01A26073
		27 mm	01A27073
		special	01BSP073

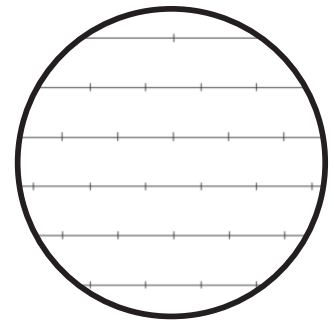

zeiss integrating eyepiece disc 100

G47 Similar to G49 but extended to 100 points, which are indexed.

pattern	description	diameter	order code
G47	Zeiss integrating eyepiece disc.t	16 mm	01A16090
		19 mm	01A19090
		21 mm	01B21090
		23 mm	01A23090
		24 mm	01A24090
		26 mm	01A26090
		27 mm	01A27090
		special	01BSP090

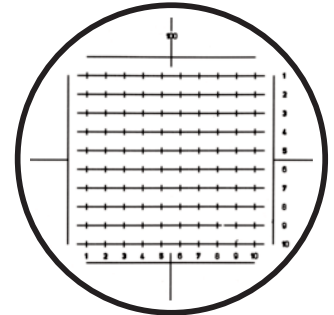

integrating eyepiece

G50 Similar to G49 but extended to 100 points, which are indexed.

pattern	description	diameter	order code
G50	Integrating eyepiece (simplified)	19 mm	01B19075
		21 mm	01B21075
		23 mm	01B19075
		24 mm	01B19075
		26 mm	01B19075
		27 mm	01B19075
		special	01BSP075

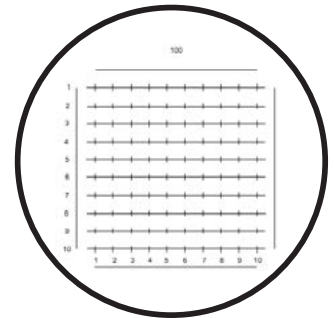

stereology

In its simplest form, stereology is the science where information about a three dimensional object is obtained from only a two-dimensional section of that structure.

Measurements are usually made with these reticles in the following manner:-

1. An adequate representation of sections of a specimen is obtained.
2. The reticle is superimposed upon the specimen (or micrograph/projected image of the section).
3. Finally, the interaction between the superimposed reticle and the test sections are recorded.

An overall introduction is given by: L.G.Briarty. "Stereology : Methods for Quantitative Light and Electron Microscopy." Sci. Prog. Oxf. 1975 62; 1-32

the mertz reticle (36 point)

NGM1 Used to estimate the three dimensional surface areas or the surface density of a component in a given volume, when the component does not have a random orientation. It comprises a test system with parallel curved lines used for measuring the intersection of points. Reference: W.A.Mertz. " Mikroskopie" Vol. 22 1967 pp 132-142.

pattern	description	diameter	order code
NGM1	Mertz for stereology	16 mm	01B16258
		19 mm	01B19258
		21 mm	01B21258
		23 mm	01B23258
		24 mm	01B24258
		26 mm	01B26258
		27 mm	01B27258
		special	01BSP258

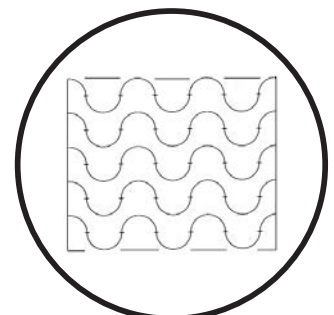

weibel 1

NGW1

drawings not to scale

15 lines of equal length connecting the verticals of a regular hexagonal point network. Reference: E.R.Weibel Lab. Invest. Vol. 22 pp131-152. Principles and Methods for the Morphometric Study of the Lung and Other Organs.

pattern	description	diameter	order code
NGW1	Weibel type 1 for stereology	16 mm	01B16259
		19 mm	01B19259
		21 mm	01B21259
		23 mm	01B23259
		24 mm	01B24259
		26 mm	01B26259
		27 mm	01B27259
		special	01BSP259

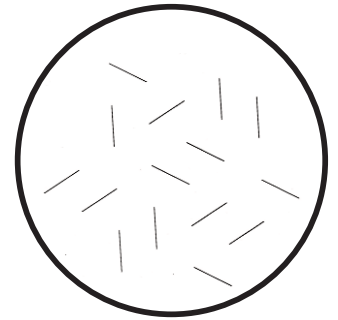

weibel 2

NGW2

Used when making a surface to volume ratio of a structure per mass unit. This reticle consists of a number of short lines with interruptions as long as the lines. Basically, the number of intersections falling over the short lines are counted and the number of endpoints falling on the end of the structure are determined.

Reference: E.R.Weibel, Journal of Microscopy Vol. 95. Pp 373-378. Current Capabilities and Limitations of Available Stereological Techniques, point counting method.

pattern	description	diameter	order code
NGW2	Weibel type 2 for stereology	16 mm	01B16260
		19 mm	01B19260
		21 mm	01B21260
		23 mm	01B19260
		24 mm	01B19260
		26 mm	01B19260
		27 mm	01B19260
		special	01BSP260

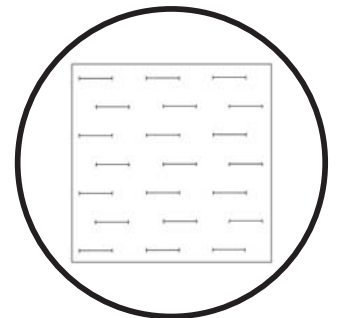

weibel 3

GW3

Reference: E.R.Weibel, G.S.Kistler & W.F.Scherle. 1966. J.Cell Biology. 30,23.

pattern	description	diameter	order code
GW3	Weibel type 3 for stereology	16 mm	01A16074
		19 mm	01A19074
		21 mm	01B21074
		23 mm	01A23074
		24 mm	01A24074
		26 mm	01A26074
		27 mm	01A27074
		special	01BSP074

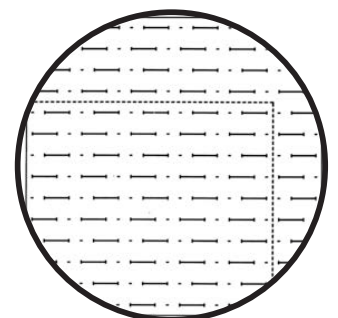

grain sizing patterns EN10247/ ISO4976

NG60, NG61

For the determination of non-metallic inclusion content of steel.

NG60 meets EN10247 & NG61 meets ISO 4967. Both are scaled for use with 10x objective magnification.

pattern	description	diameter	order code
NG60	Grain sizing reticle to EN10247.	21 mm	01B21265
		23 mm	01B23265
		24 mm	01B24265
		26 mm	01B26265
		27 mm	01B27265
	others		

pattern	description	diameter	order code
NG61	Grain sizing reticle to ISO4967	21 mm	01B21266
		23 mm	01B23266
		24 mm	01B24266
		26 mm	01B26266
		27 mm	01B27266
	others		

ASTM austenite 1:1 grain sizing disc

G41 Reference: VDEH 1510-61

pattern	description	diameter	order code
G41	ASTM grain sizing austenite	19 mm	01A19064
		21 mm	01B21064
		23 mm	01A23064
		24 mm	01A24064
		26 mm	01A26064
		27 mm	01A27064
	special		01BSP064

ASTM E112 plate 1 grain sizing disc

G42

pattern	description	diameter	order code
G42	Grain sizing E112	19 mm	01A19065
		21 mm	01B21065
		23 mm	01A23065
		24 mm	01A24065
		26 mm	01A26065
		27 mm	01A27065
	special		01BSP065

ASTM carbide grain sizing chart

G43

pattern	description	diameter	order code
G43	ASTM Grain sizing carbide	19 mm	01A19066
		21 mm	01B21066
		23 mm	01A23066
		24 mm	01A24066
		26 mm	01A26066
		27 mm	01A27066
	special		01BSP066

drawings not to scale

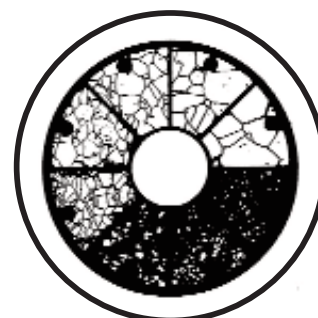
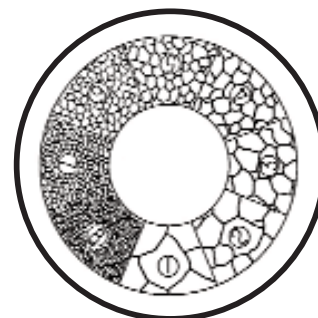
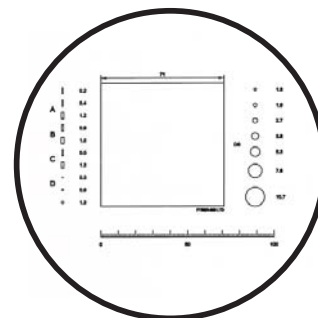
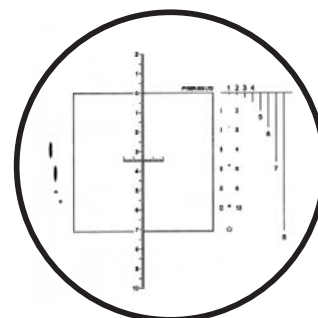

ASTM E45**G44**

For some applications customers require the square to be 10mm x 10mm.
Please state special on order for this version.

pattern	description	diameter	order code
G44	ASTM grain sizing root 2 sides	19 mm	01A19086
	7.1mm squares, 10mm scale.	21 mm	01A21086
		23 mm	01A23086
		24 mm	01A24086
		26 mm	01A26086
		27 mm	01A27086
		special	01ASP086

drawings not to scale

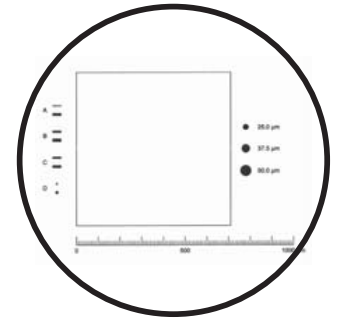
**ASTM E19-46 grain sizing - G45**

pattern	description	diameter	order code
G45	ASTM grain sizing E19-46	19 mm	01A19067
		21 mm	01B21067
		23 mm	01A23067
		24 mm </td <td>01A24067</td>	01A24067
		26 mm	01A26067
		27 mm	01A27067
		special	01BSP067

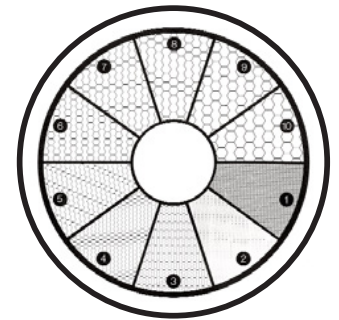
**ASTM E19-46 grain sizing disc root 2 - G46**

pattern	description	diameter	order code
G46	ASTM grain sizing E19-46	19 mm	01A19068
	Root 2	21 mm	01B21068
		23 mm	01A23068
		24 mm	01A24068
		26 mm	01A26068
		27 mm	01A27068
		special	01BSP068

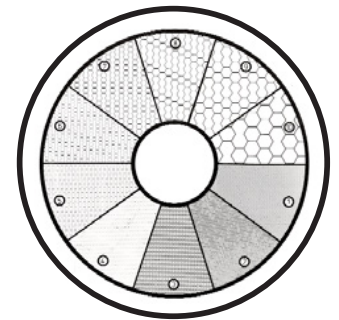
**circular grid ASTM 24 points - G54**

pattern	description	diameter	order code
G54	ASTM 24 point circular grid.	19 mm	01A19078
		21 mm	01B21078
		23 mm	01A23078
		24 mm	01A24078
		26 mm	01A26078
		27 mm	01A27078
		special	01BSP078

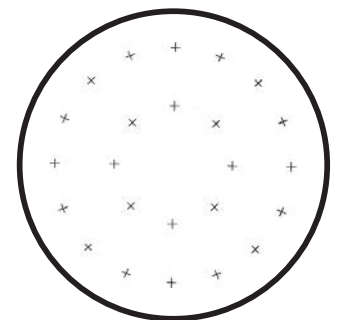
**square grid ASTM 25 points - G55**

pattern	description	diameter	order code
G55	ASTM 25 point square grid.	19 mm	01A19079
		21 mm	01B21079
		23 mm	01A23079
		24 mm	01A24079
		26 mm	01A26079
		27 mm	01A27079
		special	01BSP079

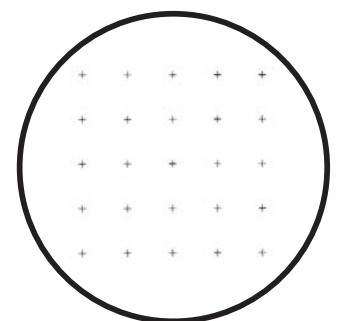

index by type

page

lines and crosses 2-3

Single Lines - NE50	2
Crosslines - NE8, NE81, NE82	2
Broken Crosslines - NE56	2
Crossed Gauge Lines	3

eyepiece scales 3-6

Horizontal & Vertical Scales - NE120, NE1, NE2, NE5, NE28, NE41, NE20, NE31	3 4
Crossed Scales - NE17, NE18, NE72, NE70	5
Scales with Crosslines - NE7, NE7N, NE77, NE777	5 6

squares & grids 6-9

Squared Grids - NE10, NE11, NE34	7
Indexed Grids - NE10A, NE11A, NE34A, NE71, NE35	7 8
Chessboard Squares - NE15	8
Squares & Grids - NE38	8
Miller Squares - NE57	8
Whipple Grid - NE29	9

circle gauges & protractors 9-10

Concentric Circles - NE42, NE43, NE44, NE47 NE48, NE22	9 10
Gauge Pairs - NE19	10
Protractors	10
Half Protractors- NE25	10
Full Protractor- NE45	10

specialist designs 14-16

Spray Droplet Sizing Reticle	14
Matthews - NG30	14
Thompson - G23	14
Chalkley Point Array - NG52	14
Pharmaceutical PSA Pattern - G57	15
Counting Pattern - NG14	15
Lennox Grain Analysis - NG21	15
Kotter - G48	15
Zeiss Integrating Eyepiece Disc 1 or	16
Henning Reseau Pattern 25 points - G49	16
Zeiss Integrating Eyepiece Disc 100 - G47	16
Integrating Eyepiece - G50	16

stereology 16-17

The Mertz Reticle (36 point) - NGM1	16
Weibel 1 - NGW1	17
Weibel 2 - NGW2	17
Weibel 3 - GW3	17

metallurgy 18-19

New Grain Sizing Patterns EN10247/ISO4976 NG60, NG61	18 18
ASTM Austenite 1:1 Grain Sizing Disc - G41	18
ASTM E112 Plate 1 Grain Sizing Disc - G42	18
ASTM Carbide Grain Sizing Chart - G43	18
ASTM E45 - G44	19
ASTM E19-46 Grain Sizing Disc - G45	19
ASTM E19-46 Grain Sizing Disc Root 2 - G46	19
Circular Grid ASTM 24 Points - G54	19
Square Grid ASTM 25 points - G55	19

other products



defence reticles

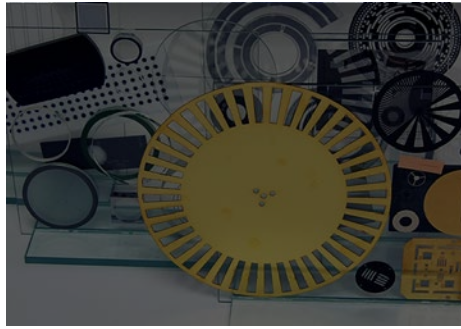

custom reticle solutions

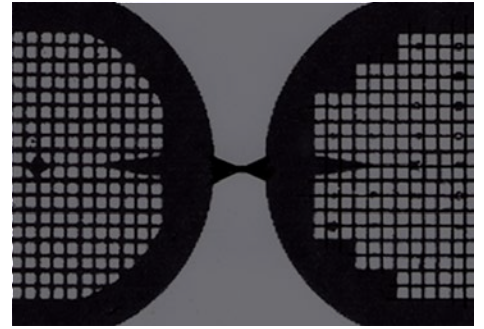

em grids



stage micrometers calibration standards



resolution charts and gratings

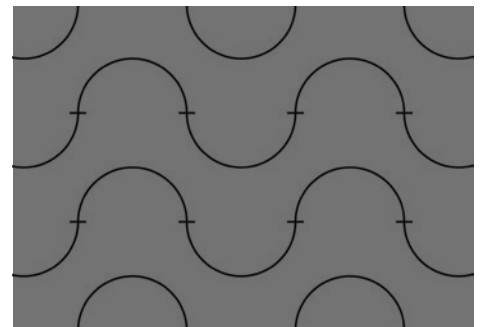

eyepiece reticles

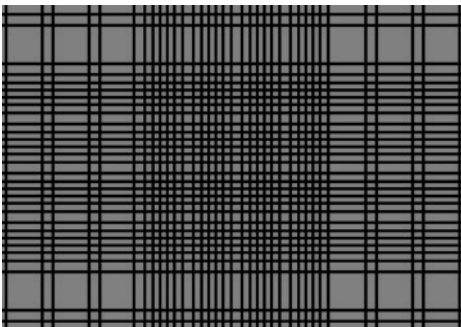

counting chambers



portable microscopes



precision apertures



mag 6 & mag 7 magnifiers

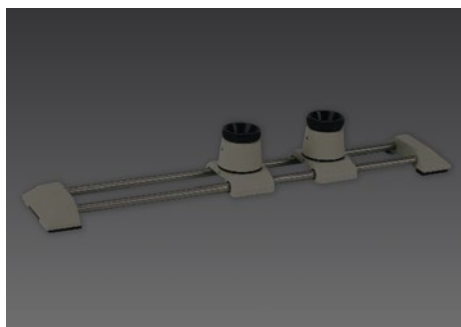

magnified measuring scales